

# MANUAL USE AND MAINTENANCE



CM 70hs Plus

ED. 10-2007

EN

Doc. 10009848



---

The contained descriptions in the present publication are not binding. The company therefore reserves itself the right to bring in whatever moment possible organs changes, details or supplies of accessories, that it holds convenient for an improvement, or for any demand of constructive or commercial character.

The partial reproduction of the texts and diagrammes contained in the present catalog, is forbidden by law.

---

The company reserves itself the right to bring changes of technical character and/or of endowment. The images are meant of pure reference and not binding in terms of design and endowment.

---

#### **Symbols used in the manual**

---



Symbol of the book open with letter i  
It points out that this document is a manual of instructions.

---

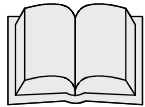

Symbol of the open book  
It points out to the operator to read the manual of use before using the machine.

---



Symbol of warning  
Read attentively the sections preceded by this symbol for the safety of the operator and the machine

---



## TABLE OF CONTENTS

<b>RECEIVING THE MACHINE</b> .....	<b>4</b>
<b>IDENTIFICATION PLATE</b> .....	<b>4</b>
<b>FOREWORD</b> .....	<b>4</b>
<b>TECHNICAL DESCRIPTION</b> .....	<b>5</b>
<b>SYMBOLS USED ON THE MACHINE</b> .....	<b>6</b>
<b>GENERAL SAFETY REGULATIONS</b> .....	<b>8</b>
<b>PREPARING THE MACHINE</b> .....	<b>9</b>
1. MOVING THE PACKAGED MACHINE .....	9
2. HOW TO UNPACK THE MACHINE .....	9
3. PUTTING THE BATTERIES IN THE MACHINE .....	10
4. TYPE OF BATTERY .....	10
5. BATTERY MAINTENANCE .....	10
6. DISPOSAL METHODS .....	11
7. CONNECTING THE BATTERY CHARGER .....	11
8. BATTERY RECHARGING .....	11
9. CONNECTING THE BATTERY CONNECTOR .....	12
10. BATTERY CHARGE LEVEL GAUGE .....	12
11. INSTALLING THE PAD .....	12
<b>OPERATION</b> .....	<b>13</b>
PREPARING TO WORK .....	13
TRACTION .....	14
BRAKES .....	14
POLISHING PAD MOTOR .....	14
FLASH LIGHT .....	15
HORN .....	15
PRESSURE CHECK .....	15
SUCTION .....	15
<b>AFTER WORK IS TERMINATED</b> .....	<b>16</b>
<b>DAILY MAINTENANCE</b> .....	<b>17</b>
REPLACING THE DUST FILTER .....	17
REMOVING THE PAD DISK .....	17
<b>EXTRAORDINARY MAINTENANCE</b> .....	<b>18</b>
REPLACING THE BASE SPLASHGUARDS .....	18
<b>SOLUTION FOR THE MOST FREQUENT TROUBLES</b> .....	<b>19</b>
MACHINE DOES NOT START .....	19
BRUSH MOTOR DOES NOT OPERATE .....	19
HORN DOES NOT OPERATE .....	19
IMPOSSIBLE TO LIFT OR LOWER THE BASE .....	19
ELECTRICAL FUSES AND THERMAL CUTOUTS .....	20
SUCTION IS ABSENT OR DEFECTIVE .....	20
<b>SELECTING AND USING POLISHING PADS</b> .....	<b>21</b>
<b>WASTE DISPOSAL</b> .....	<b>22</b>
<b>EC DECLARATION OF CONFORMITY</b> .....	<b>23</b>



---

## Receiving the machine

---

Immediately check, when receiving the machine, that all the materials indicated on delivery documents have been received and also that the machine has not been damaged in transit. If it has been damaged, this damage must be immediately reported to the shipper and also to our customer's service department. Only acting promptly in this manner will make it possible to receive missing material and to be compensated for damage.

---

## Identification plate

---



---

## Foreword

---

This is a floor scrubbing machine that is able to clean any type of floor by using the mechanical action of the rotating brush and the chemical action of the water-detergent solution. As it moves forward it also gathers up the dirt removed and the detergent solution that has not been absorbed by the floor. **The machine must only be used for this function.** Even the best machines will only operate efficiently and work with profit if they are used properly and kept in perfect operating order. Read this instruction booklet carefully and consult it every time problems arise with machine operation. Remember that, if necessary, our service organization, in collaboration with our dealers, is always available for helpful hints or direct intervention.



<b>TECHNICAL DESCRIPTION</b>	<b>U/M</b>	<b>CM 70 hs Plus</b>
Working width	mm	690
Work capacity, up to	m <sup>2</sup> /h	4140
Disk brush (No. 1)	∅ mm	690
Brush revolutions	RPM	1300
Brush motor	W	5000
Pressure on the brush	kg	15
Traction motor	W	600
Traction wheel	∅ mm	250
Forward speed	km/h	0÷6
Maximum slope when fully loaded	%	10
Elastic front wheels	∅ mm	300x90
Bin capacity	l	18,5
Suction	L/s	40
Suction motor	Watt	500
Turning circle	mm	2040
Machine length	mm	1700
Machine height	mm	1443
Machine width	mm	780
Battery compartment	mm	560x640xH460
Rated battery voltage	V	36
Battery capacity (C5)	Ah	320
Battery weight	kg	306
Machine weight (empty and without batteries)	kg	336



## SYMBOLS USED ON THE MACHINE

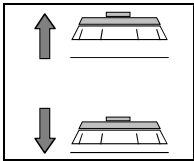

Base lift-lower symbol  
Used to indicate the base lift-lower switch

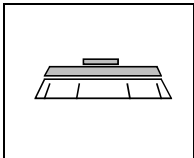

Symbol showing the polishing pad is working.  
Used to indicate the switch that starts the polishing pad motor.

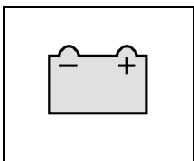

Battery charge level symbol

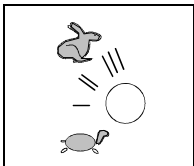

Forward/reverse speed selector symbol

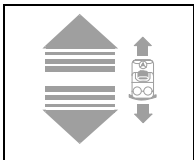

Forward/reverse selector symbol

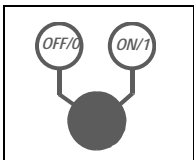

Main switch symbol (key-operated switch)

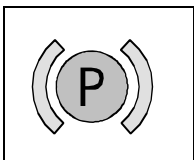

Brake symbol  
Used to indicate the signal lamp of the engaged hand brake  
Used above the emergency brake lever

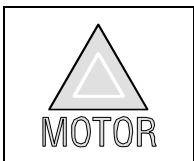

Ampere monitoring symbol for the polishing pad motor (red signal lamp).  
The signal lamp turns on when the motor is under stress.

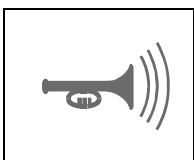

Symbol indicating the horn push-button



## SYMBOLS USED IN THE MANUAL



Warning symbol

Read sections preceded by this symbol with care: they concern the safety of the operator and the machine



Indicates danger of gas fumes and leakage of corrosive liquids

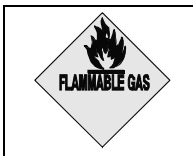

Indicates danger of fire

Do not approach with open flames



Indicates the waste disposal.

Keep the regulations. .



## GENERAL SAFETY REGULATIONS

**Follow these regulations carefully to avoid harm to the operator and damage to the machine.**

- Read the labels on the machine carefully. Never cover them for any reason and immediately replace them if they are damaged
- The machine must be used exclusively by authorized and trained personnel
- When operating the machine be careful of other persons and of children in particular
- Never mix different types of detergents: this could generate noxious gases
- Never set containers of liquid on the machine
- Machine storage temperature must be between -25°C and +55°C
- Operating conditions: room temperature between 0°C and 40°C with relative humidity between 30 and 95%.
- Never use the machine in an explosive environment
- Never use the machine to transport goods
- Never use acid solutions which could damage the machine and/or persons
- Avoid running the pads with the machine stopped: this could damage the floor
- Never suck flammable liquids
- Never use the appliance to collect dangerous powders.
- Use a powder fire extinguisher in case of fire. Do not use water
- Do not hit against shelving or scaffolding when there is a danger of falling objects
- Suit operating speed to traction conditions
- Do not use the appliance on surfaces with a slope higher than the one indicated on the name-plate.
- Whenever you park the machine remove the key and apply the parking brake
- Whenever the machine has operating troubles make sure these are not due to insufficient ordinary maintenance. If this is not the case then enquire with your nearest **COMAC** service center
- When replacing machine parts always ask for ORIGINAL spare parts from your Authorized **COMAC** dealer and/or Retailer
- Use only original **COMAC** polishing pads
- Immediately engage the emergency lever in case of danger (connector placed below the machine operator)
- Always cut off the electric power supply to the machine whenever maintenance is performed
- Restore all electrical connections after terminating any maintenance procedures
- Never remove guards that require tools for removal
- Never wash the machine with direct or pressurized jets of water or with corrosive substances
- Have your nearest **COMAC** service center check the machine every 200 operating hours
- Before you use the machine make sure that all doors and covers are positioned as shown in this operating and maintenance manual
- Dispose of consumables in accordance with currently applicable laws and codes
- When, after years of precious work, your **COMAC** machine is ready to be retired all of its component materials must be properly disposed of: they contain oils, batteries and electronic components. Remember that the machine itself was built using totally recyclable materials.





## PREPARING THE MACHINE

### 1. MOVING THE PACKAGED MACHINE

The machine is contained in specific packing with a platform so that it can be moved by a fork-lift. Packings cannot be stacked.

Total weight is 400 kg (without batteries)

Packing dimensions are:

- A : 1550 mm
- B : 1000 mm
- C : 1740 mm

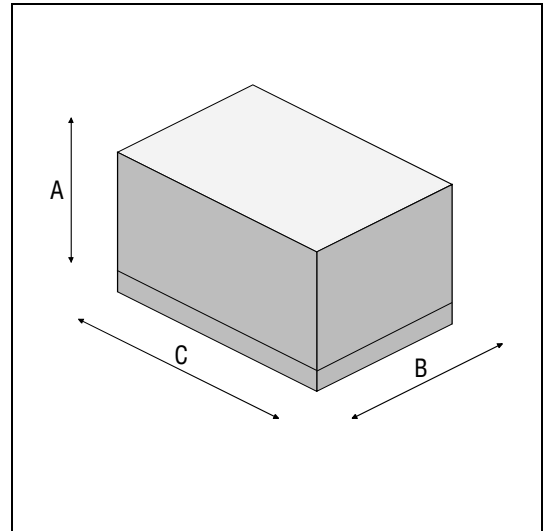

### 2. HOW TO UNPACK THE MACHINE

1. Remove the outer packing.
2. The machine is fastened to its platform by wedges that clamp its wheels.
3. Remove the wedges.

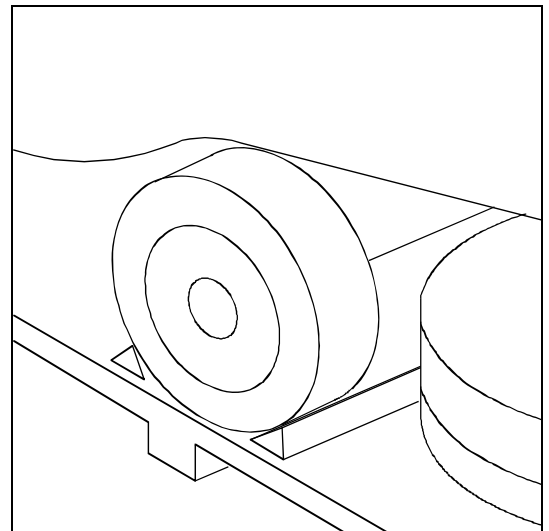

4. Use a ramp to lower the machine off the platform, pushing it in reverse.
5. Keep the platform since it may be necessary to transport the machine again.

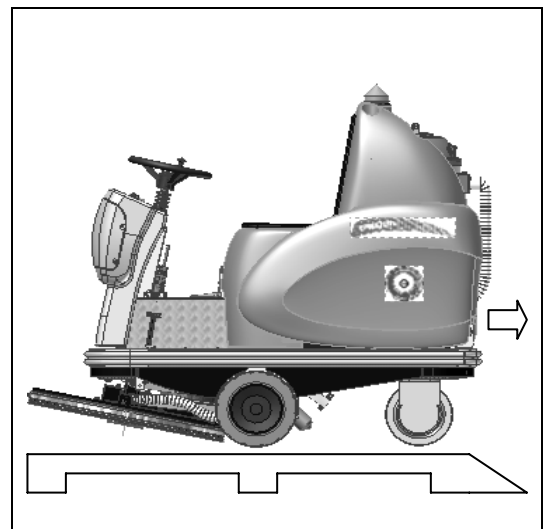



## PREPARING THE MACHINE

### 3. PUTTING THE BATTERIES IN THE MACHINE

The batteries must be housed in the battery compartment below the seat panel and must also comply with the requirements given in CEI 21-5 standards.

Battery compartment dimensions are: 540x640 H460 mm.

When inserting the battery:

1. Open the hook (3), lift the seat – bonnet tacking hold of it under (1) and set up safety prop (2).
2. Position the batteries

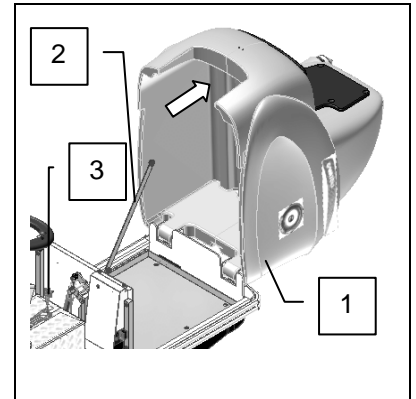

### 4. TYPE OF BATTERY

The machine must be powered using:

- flat or tubular plate lead-acid traction batteries with free electrolyte;
- gel-technology gas recombination hermetically sealed traction batteries.

**NO OTHER TYPES CAN BE USED.**

Each battery is composed of DIN cells connected in series and supplying 6V voltage across the terminals.

Maximum weight and dimensions are:

width 178 mm, length 295 mm, height 424 mm; weight 51kg

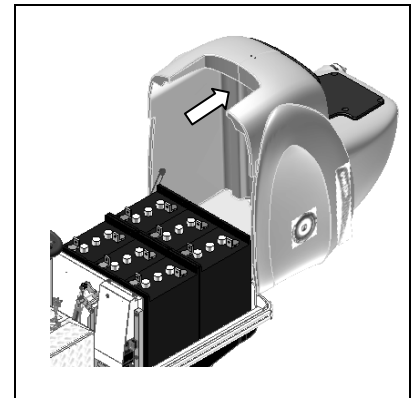

These must be handled using transport and hoisting equipment suitable for their size and weight.

Lift using the handles on the top.

They must be housed in the battery compartment with connection terminals directed towards the rear of the machine.

They must be connected in series together in order to have a 36V voltage across terminals. Electrical connections must be made by trained and specialized personnel from the COMAC Service Center.

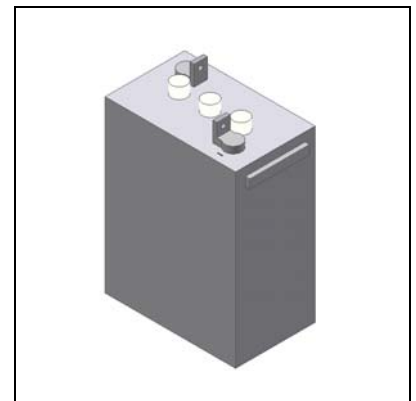

### 5. BATTERY MAINTENANCE

Comply with the battery manufacturer's instructions for battery maintenance and recharging.

Pay special attention when selecting the battery charger: it differs according to battery type and capacity.



## PREPARING THE MACHINE

### 6. DISPOSAL METHODS

When the battery is run down it must be disconnected by trained and specialized personnel and then lifted using the handles on it and suitable hoisting equipment to remove it from the battery compartment.

RUN-DOWN BATTERIES ARE CLASSIFIED AS HAZARDOUS WASTE AND MUST BE GIVEN TO A LEGALLY AUTHORIZED DISPOSAL AGENCY.

### 7. CONNECTING THE BATTERY CHARGER

The connector is located low down compared to the driver's seat. Left part (1), connected to the batteries, must be detached from machine connector (2) and hooked up to the battery charger connector for charging. Hook-up connector (3) is delivered inside the bag that contains this instruction booklet. It must be first connected to battery charger cables according to instructions (refer to the battery charger manual).



**WARNING!** This procedure must be done by qualified personnel. A mistaken or imperfect cable connection to the connector can cause severe damage to persons or property

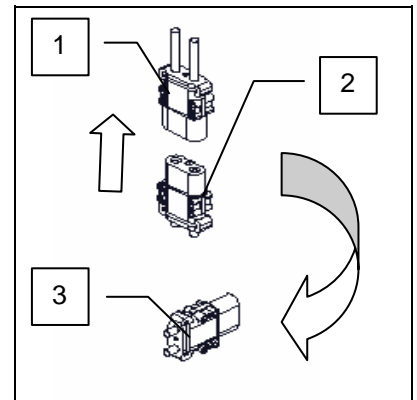

### 8. BATTERY RECHARGING

Prevent permanent damage to the batteries by making sure they are never totally discharged. Recharge them just a few minutes after the flashing battery discharged signal starts to flash.



**NOTE:** Never leave the batteries totally discharged even if the machine is not being used. Keep the seat panel raised using safety prop as illustrated when recharging the batteries. Make sure the battery charger is suitable for the type and capacity of the batteries that are installed.

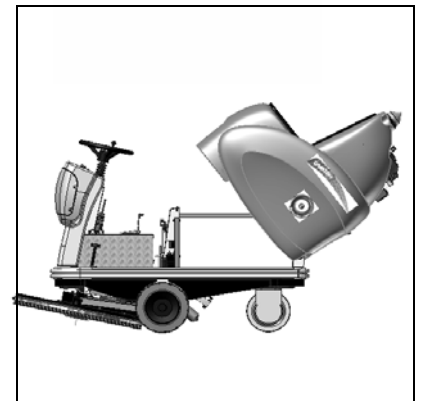

**Danger of gas fumes and leakage of corrosive liquids.**



**Danger of fire: Do not approach with open flames**



## PREPARING THE MACHINE

### 9. CONNECTING THE BATTERY CONNECTOR

Battery connector (1) must be connected to machine connector (2)

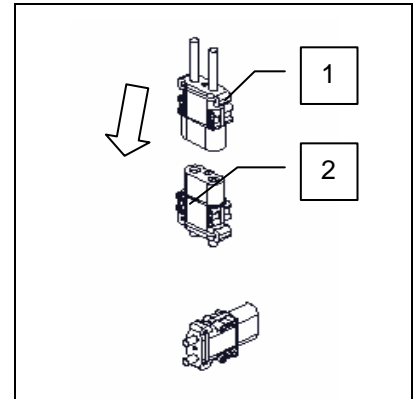

### 10. BATTERY CHARGE LEVEL GAUGE

The battery charge level gauge is a digital unit with 4 fixed and one flashing position. The numbers on the display give an approximate idea of the state of charge:

**4** = maximum charge, **3** = 3/4 charge, **2** = 2/4 charge, **1** = 1/4 charge, **0** = batteries discharged (flashing)



**WARNING!** The pad motor automatically turns off a few seconds after the flashing "0" appears. The remaining charge can be used to move the machine to the recharging point.

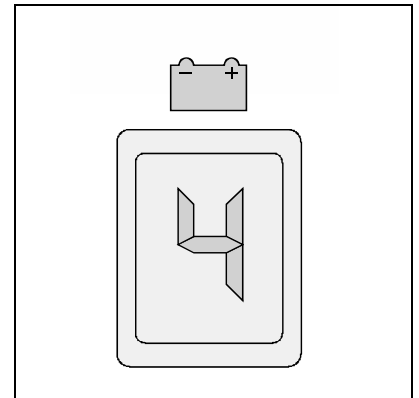

### 11. INSTALLING THE PAD

1. Connect the battery connector
2. Turn the key to "1"
3. Operate the lever to lift the base
4. Turn the key to "0" and pull it out from the dashboard



**WARNING!** Make sure no persons or objects are in the vicinity of the pad base when doing this.

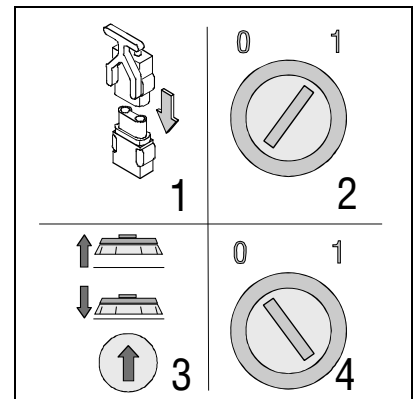

5. Keep the base in its raised position. Unscrew (rotating counterclockwise) ring (1). Install pad (2) on the disk drive plate. Use one hand to support the pad and the other to tighten the fastening ring (rotating it clockwise).



**WARNING!** Wear suitable safety gloves before installing the pad.

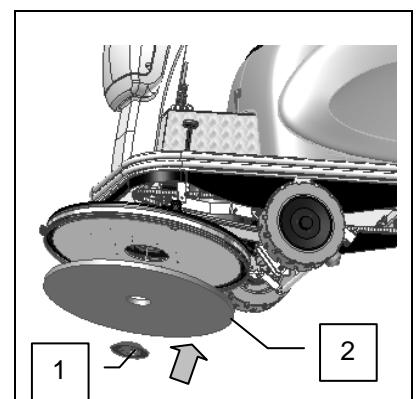



## OPERATION

### PREPARING TO WORK

1. Prepare the machine for operation
2. Check that suction unit switch (1) is set to "ON" and make sure the paper filter is installed.
3. Sit in the driver's seat
4. Check that the parking brake is released (1)
5. Turn main switch key (3) clockwise to "1". Display (4) on the dashboard will immediately turn on and indicate the level of the battery charge and the hour counter.

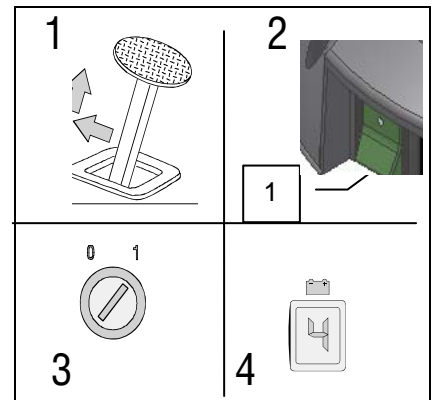

6. Press base lift-lower switch (5) down to lower the base; press polishing pad switch (6) (green signal lamp on).

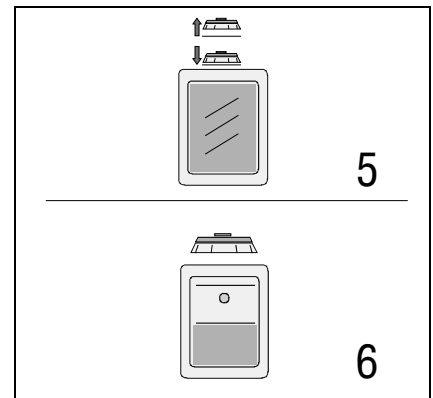

7. Select forward speed turning knob (7). The selector has three positions, indicated by symbols: turtle = slow speed, middle position = normal speed, rabbit = fast speed
8. Select the drive direction on switch (8)
9. The machine starts to move when you press accelerator pedal (9). The base will start to lower and the polishing pad will start to rotate when it is totally lowered down (the base lifts up a few centimeters and the pad stops when the accelerator pedal is released)
10. Check work quality during the first few meters of work.

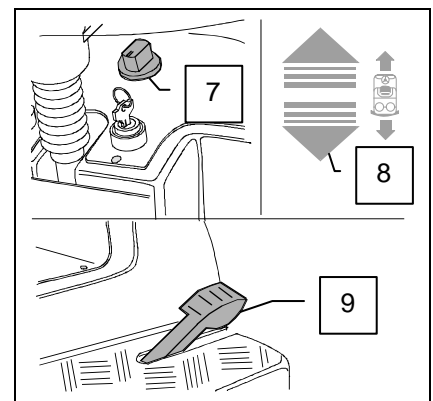

**Whenever problems arise during operation turn off key (1), quickly detach emergency lever (2) placed below the operator and set the emergency brake by pushing lever (3) down and pulling it towards yourself until it hooks up.** These procedures will block all machine movements. To start working again, after you have solved the problem, reconnect connector (2), turn key (1) and release parking brake lever (3).

**The machine will not move if the operator is not firmly seated on the seat.**

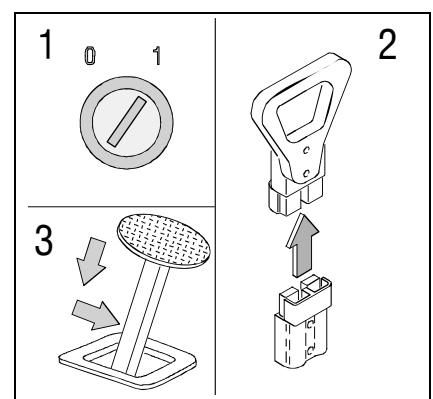



## OPERATION

A “flashing zero” appears on the display when the battery charge level is getting too low. The pad motor automatically turns off. Batteries must be recharged as soon as possible.

A residual charge remains so as to move the machine to the recharging point.

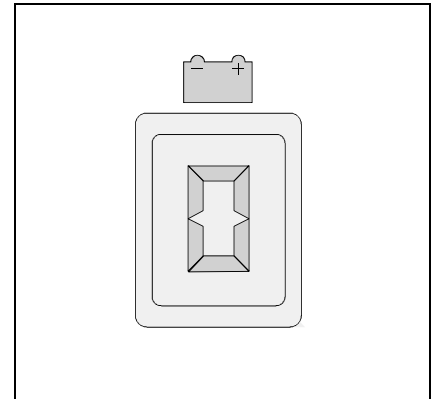

### TRACTION

This machine has an electronically controlled traction with three forward and three reverse speeds. To move the machine first turn the key and then move the switch forward (to move forward) or backward (to move in reverse). Press the accelerator pedal and the machine will start to move. Rotate selector to adjust forward movement speed.

An audio signal will sound when the machine is moving in reverse.

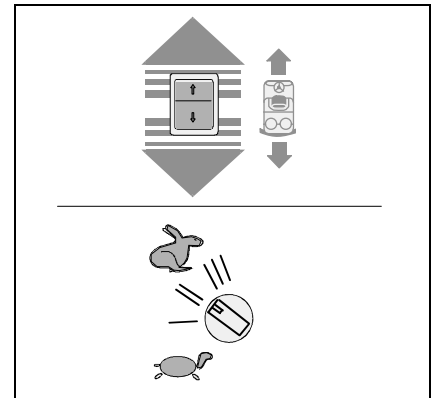

### BRAKES

The machine has an electronic braking system. To brake, in normal conditions, just release the accelerator pedal. Actuate the pedal-operated mechanical brake whenever the service brake operates poorly or whenever necessary (parking, danger, etc.). Actuate by pushing the pedal down and pulling it towards yourself until lever (1) hooks up (the red brake signal lamp turns on when the lever is hooked up).

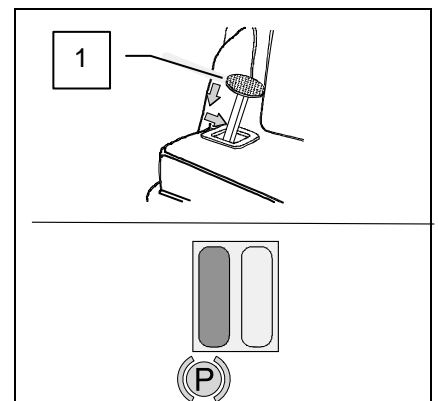

### POLISHING PAD MOTOR



**WARNING!** The pad motor starts only when the machine is moving forward in order to prevent damage to the floors

The pad motor is electronically controlled. The red signal lamp on the dashboard starts to flash when preset overload limits are reached. After a few seconds the motor will stop and the pad switch signal lamp will turn off. To start the motor up again you must turn the main switch key off and on. If the motor stops again you must find the cause of the overload to prevent damage to the motor.

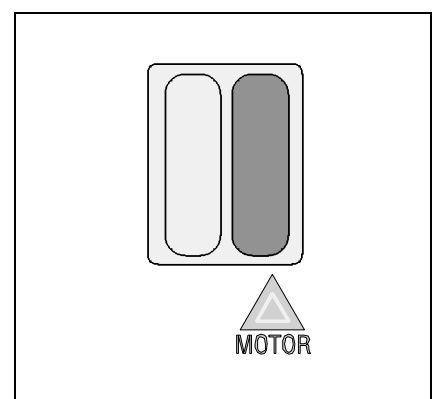



## OPERATION

### FLASH LIGHT

The machine has a flash light that turns on automatically when the main switch key is turned.

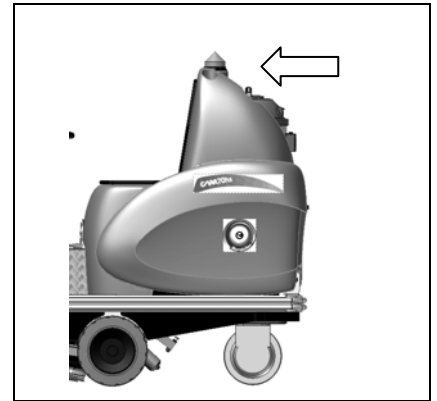

### HORN

The machine has a horn actuated by push-button (1) at the left of the steering column. The horn also functions to signal reverse motion. The horn's push-button is deactivated during reverse motion.

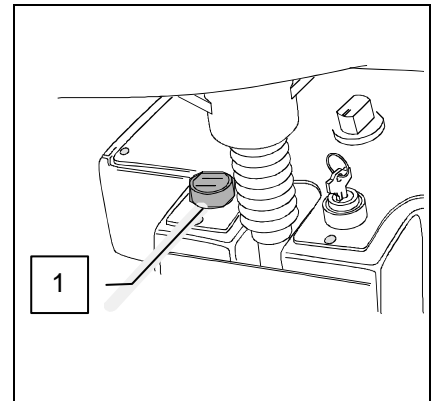

### PRESSURE CHECK

The machine has a system that checks the pressure at the pad at three levels, controlled by knob (1) placed on the right side of the steering column. The pressure check optimizes work when cleaning irregular floors.

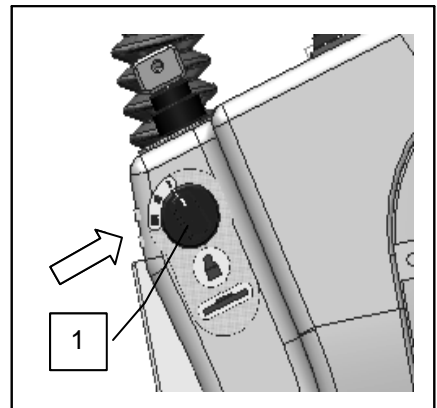

### SUCTION

The machine has a suction unit connected to its drive system and operating when switch (1) is in its "ON" position.

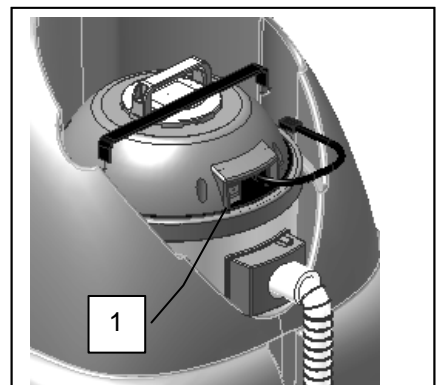



## AFTER WORK IS TERMINATED

At the end of the work, before performing any type of maintenance proceed as follows :

1. Turn pad motor switch (1) off
2. Actuate switch (2) to lift the base
3. Park the machine and actuate the parking brake
4. Turn the key to position "0" to turn the machine off

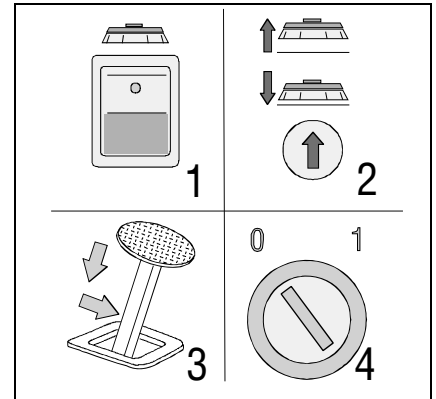

5. Detach suction connector (1), pull out suction tube (2), remove suction unit fastening belt (3) and pull out suction unit (4).



**WARNING!** Always wear gloves when doing this to protect yourself from contact with hazardous solutions.

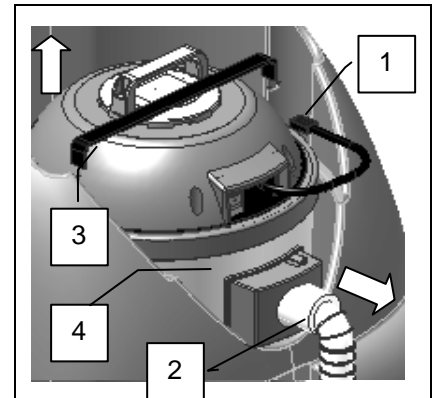

6. Loosen the hooks on drum (7).
7. Remove head (8).
8. Replace paper filter (9).
9. Put the head back in and fasten it on the drum with its hooks. Put the suction unit back in its compartment, insert the flexible tube in the nozzle and then reattach the connector.
10. Dismantle the brushes and clean them with a jet of air (to dismantle the brushes refer to the section "DISMANTLING THE BRUSH

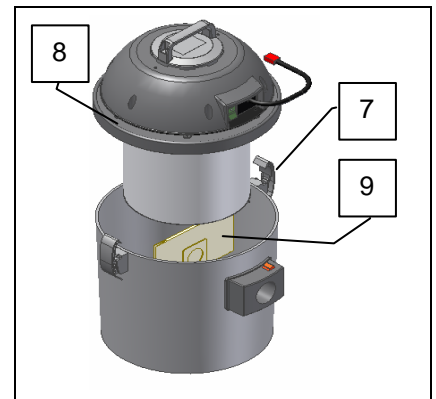





## DAILY MAINTENANCE

### REPLACING THE DUST FILTER

11. Detach suction connector (1), pull out suction tube (2), remove fastening belt (3), pull out suction unit (4).



**WARNING!** Use gloves when doing this to protect yourself against contact with dangerous liquids.

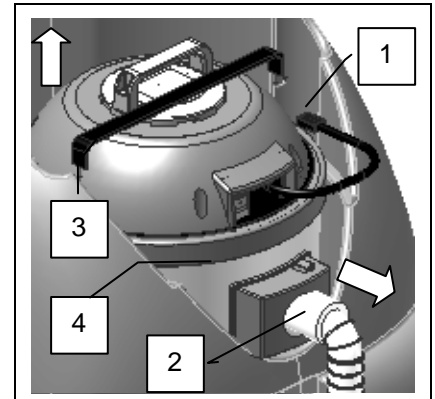

12. Loosen the hooks on drum (7).
13. Remove head (8).
14. Replace paper filter (9).
15. Put the head back in and fasten it onto the drum with its hooks. Put the suction unit back in its compartment, insert the flexible tube in the nozzle and then reattach the connector.
16. Clean the drum. Do not leave dust in the drum for long time periods.
17. Dismantle the brushes and clean them with a jet of air (to dismantle the brushes refer to the section "DISMANTLING THE BRUSH").

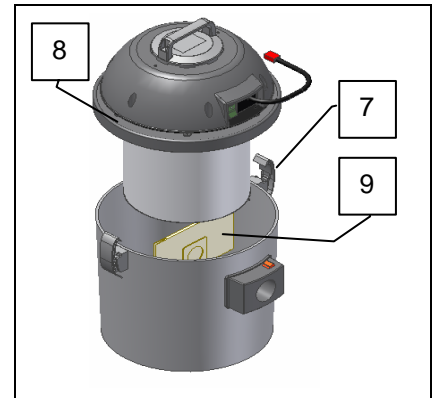

### REMOVING THE PAD DISK

1. Connect the battery connector if it is not connected
2. Turn the key to position "1"
3. Use the control switch to lift the base (if it isn't already lifted)
4. Turn the key to "0" and pull it out from the dashboard (hand injuries may be caused if the brush is removed with power on)



**WARNING!** Make sure there are no objects or persons in the vicinity of the brush when doing this.

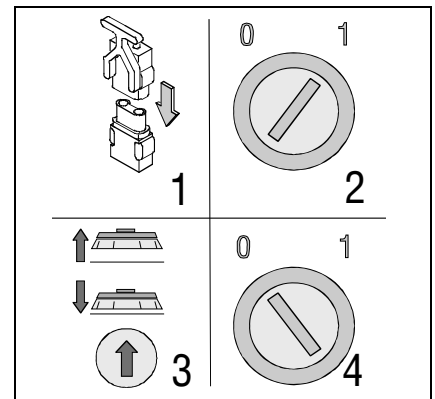

6. Keep the base in its raised position. Unscrew ring (1) (rotating counterclockwise), remove pad (2) from the drive disk, retighten the disk fastening ring (rotating clockwise).

**WARNING!** Wear gloves when doing this to protect yourself against possible contact with dangerous materials and liquids.

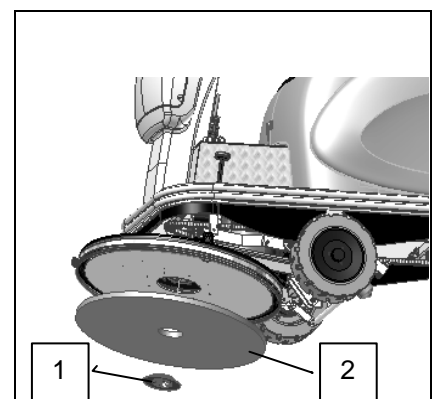



## EXTRAORDINARY MAINTENANCE

### REPLACING THE BASE SPLASHGUARDS

Periodically check the state of wear of the base splashguards. To replace them proceed as follows:

1. Lift the base
2. Install the pad
3. Lower the base until it touches the floor
4. Turn the key to "0" and pull it out from the dashboard
5. Loosen nut (1) and pull out the splashguard blade (2)
6. Remove the splashguard rubber and replace it
7. Reinstall everything by performing these procedures in reverse order. Make sure the rubber touches the floor

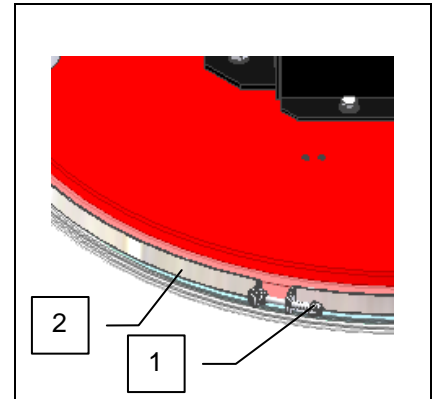



## SOLUTION FOR THE MOST FREQUENT TROUBLES

### MACHINE DOES NOT START

1. The operator must be seated on the driver's seat
2. Check that parking brake pedal (1) is released
3. Check that connector (2) is connected to the batteries
4. Check that key-operated switch (3) is on
5. Check signal device (4) to make sure the batteries are charged
6. Check that no thermal cutout has tripped (see ELECTRICAL FUSES AND THERMAL CUTOUTS)

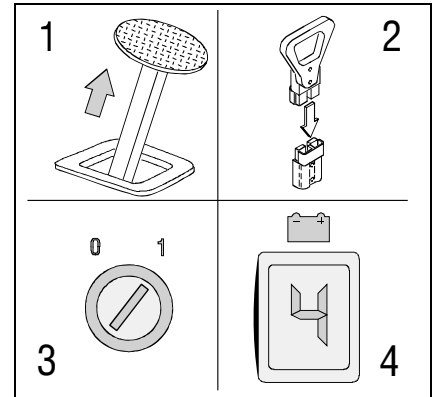

### BRUSH MOTOR DOES NOT OPERATE

**WARNING** The motor only starts when the machine is moving forward in order to prevent damage to the floors

1. Check that the base is lowered down
2. Check that the motor signal lamp is on (1)
3. Check the signal device to make sure the batteries are charged
4. Check that no thermal cutout has tripped.

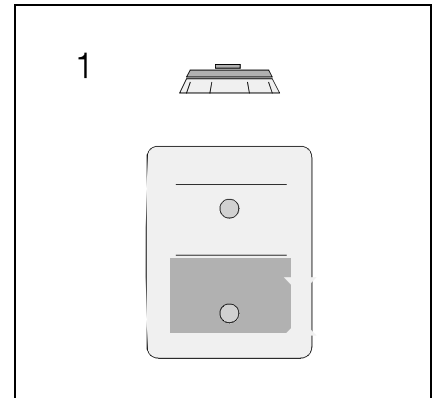

### HORN DOES NOT OPERATE

Check that a thermal cutout has not tripped (see ELECTRICAL FUSES AND THERMAL CUTOUTS).

### IMPOSSIBLE TO LIFT OR LOWER THE BASE

Check that a thermal cutout has not tripped (see ELECTRICAL FUSES AND THERMAL CUTOUTS)



## SOLUTION FOR THE MOST FREQUENT TROUBLES

### ELECTRICAL FUSES AND THERMAL CUTOUTS

The machine is equipped with the following electrical protection systems:

- Power fuses placed on the machine left side to protect against short-circuits. Whenever a fuse blows check for the causes of the malfunction carefully and eliminate them before replacing the fuse.
- Low-current resettable fuses to protect:
  - General services
  - Horn
  - Traction control system

When a resettable fuse trips first turn the key to OFF (1), wait a few seconds and then turn the key to ON (2).

Turn to your authorized COMAC Service Center if the problem persists.

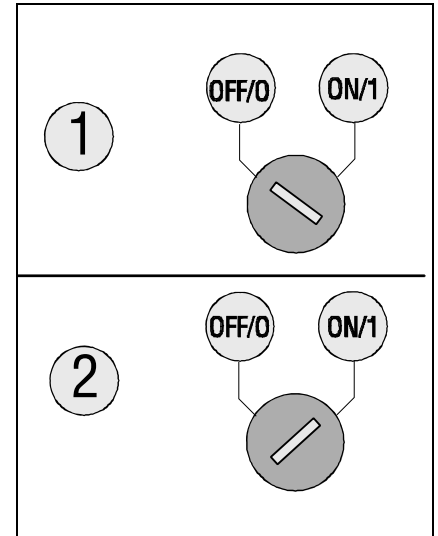

### SUCTION IS ABSENT OR DEFECTIVE

1. Check that the switch is on.
2. Clean or replace filters when suction is insufficient.
3. The suction tube is clogged. Turn the appliance off and eliminate the parts that clog the tube.
4. The suction nozzle is clogged. Turn the appliance off and eliminate the parts that clog the nozzle.



## SELECTING AND USING POLISHING PADS

### POLISHING PAD

Machine	No. of Pads	Pad diameter	
CM 70hs	1	686	



## WASTE DISPOSAL



Product subject to WEEE 2002/96/CE normative





## EC DECLARATION OF CONFORMITY

The undersigned firm:

**COMAC S.p.A.**

Via Cà Nova Zampieri 5

37057 San Giovanni Lupatoto - Verona (VR) - ITALY

declares under its own responsibility that the machine

### **SCRUBBING MACHINE mod. VISPA 35B**

is in conformity with the following Directives:

- 98/37/CEE: Machinery Directive.
- 73/23/CEE: Low Voltage Equipment Directive and its amendment 93/68/CEE.
- 89/336/CEE: Directive on Electromagnetic Compatibility and its amendments 91/263/CEE, 92/31/CEE e 93/68/CEE.

Then it is in conformity with the following standards:

- EN 60335-1: Safety of household and similar electrical appliances - Part 1: General requirements.
- EN 60335-2-72: Safety of household and similar electrical appliances - Part 2: Particular requirements for automatic machines for floor treatment for commercial and industrial use.
- EN 60335-2-29: Household and similar electrical appliances - Safety - Part 2-29: Particular requirements for battery chargers.
- EN 12100-1: Safety of machinery - Basic concepts, general principles for design - Part 1: Basic terminology and methodology.
- EN 12100-2: Safety of machinery - Basic concepts, general principles for design - Part 2: Technical principles.
- EN 55014-1: Electromagnetic compatibility - Requirements for household appliances, electric tools and similar apparatus - Part 1: Emission.
- EN 55014-2: Electromagnetic compatibility - Requirements for household appliances, electric tools and similar apparatus - Part 2: Immunity - Product family standard.
- EN 55022: Information technology equipment - Radio disturbance characteristics - Limits and methods of measurement.
- EN 61000-6-2: Electromagnetic compatibility (EMC) - Part 6-2: Generic standards - Immunity for industrial environments.
- EN 61000-6-3: Electromagnetic compatibility (EMC) - Part 6-3: Generic standards - Emission standard for residential, commercial and light-industrial environments.
- EN 61000-3-2: Electromagnetic compatibility (EMC) - Part 3-2: Limits - Limits for harmonic current emissions (equipment input current  $\leq$  16A per phase).
- EN 61000-3-3: Electromagnetic compatibility (EMC) - Part 3-3: Limits - Limitation of voltage changes, voltage fluctuations and flicker in public low-voltage supply systems, for equipment with rated current  $\leq$  16A per phase and not subject to conditional connection.
- EN 50366: Household and similar electrical appliances - Electromagnetic fields - Methods for evaluation and measurement.

San Giovanni Lupatoto, 05/02/2007

COMAC S.p.A.  
President  
Giancarlo Ruffo

**COMAC spa**

Via Cà Nova Zampieri,5 – 37057 San Giovanni Lupatoto – Verona – ITALY

Tel. +39 045 8774222 – Fax +39 045 8750303 – E-mail: [com@comac.it](mailto:com@comac.it) o [info@comac.it](mailto:info@comac.it) - [www.comac.it](http://www.comac.it)